

## Test Report

Client

Hauff-Technik GmbH & Co. KG  
Giengener Straße 35  
89428 Syrgenstein - Landshausen

Order no.

A 9072-3 / 2009

Date of contract : September 3<sup>rd</sup>, 2009

Contract : Testing of the water-tightness of a sealing system

System HSI 150-K2 packing with installed sealing cover HSI 150-D

Delivery of test items : Client

Date of receipt of test items : November 17<sup>th</sup>, 2009

Testing period : November 18<sup>th</sup> – 19<sup>th</sup>, 2009

Augsburg, January 28<sup>th</sup>, 2010  
cl/di

Department Manager

*i.V. H. Dietrich*  
Holger Dietrich



Laboratory Manager

*Hendrik Zaus*  
Hendrik Zaus

This Test Report consists of 8 pages  
It may only be published unabridged  
The test results relate only on the items tested. The test material is dissipated.

## CONTENTS

	page
<b>1 General .....</b>	<b>3</b>
<b>2 Test procedure.....</b>	<b>4</b>
2.1 Test preparation (Hauff-Technik).....	4
2.2 Test procedure (Kiwa Bautest) .....	4
<b>3 Test results .....</b>	<b>7</b>
<b>4 Summary .....</b>	<b>8</b>

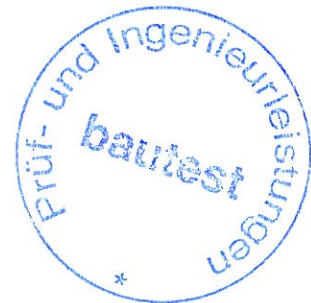

## 1 General

Kiwa Bautest GmbH was contracted by Hauff-Technik GmbH & Co. KG to evaluate the water tightness of a house lead-in for supply lines.

Therefore a prefabricated test setup with the double packing HSI 150-K2 and the sealing cover HSI 150-D was delivered by Hauff-Technik GmbH & Co. KG to our test laboratory in Augsburg.

All tests were carried out by employees of our according to DIN EN ISO / IEC 17 025 chartered laboratory in Augsburg.

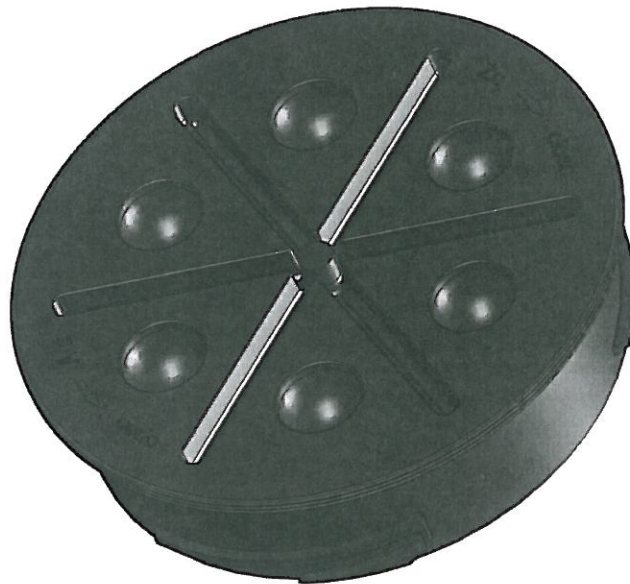

Figure 1: sealing cover HSI 150-D (Manufacturer drawing)



## 2 Test procedure

### 2.1 Test preparation (Hauff-Technik)

According to the Manufacturer information the test setup was pre-assembled by the Manufacturer as follows:

A double packing HSI 150-K2 was encased in a concrete test member (ca. 65 x 65 x 20 cm).

In addition to that a sealing cover HSI 150-D was prepared and installed.

Furthermore a compression bell with manometer, pressure regulator and rubber ring seal was provided by the Manufacturer. The compression bell is designated to be put on the test member and pressed against the concrete by four tension rods (see Figure 2).

### 2.2 Test procedure (Kiwa Bautest)

The test member which was delivered by the Manufacturer was a pre-assembled concrete test member with a test setup in accordance with section 2.1 and with a pre-assembled manometer and pressure regulator (see Figure 2 to Figure 4). A calibration of the manometer and the pressure regulator was not carried out by Kiwa Bautest GmbH.

After consultation with the Manufacturer a tightness test with a water filled pressure bell over a period of 24 hours with a nominal pressure of 2,5 bar was carried out. The filling of the pressure bell with water was carried out until the water-level reached the inlet and the air bleed valve respectively.

The torque moment of the tension rod fixtures was determined at the beginning of the test with 40 Nm. The torque moment was controlled after half of the test duration.

Minor pressure fluctuations concerning the hygroscopic properties of the concrete or the temperature volume change of the water may not be excluded.

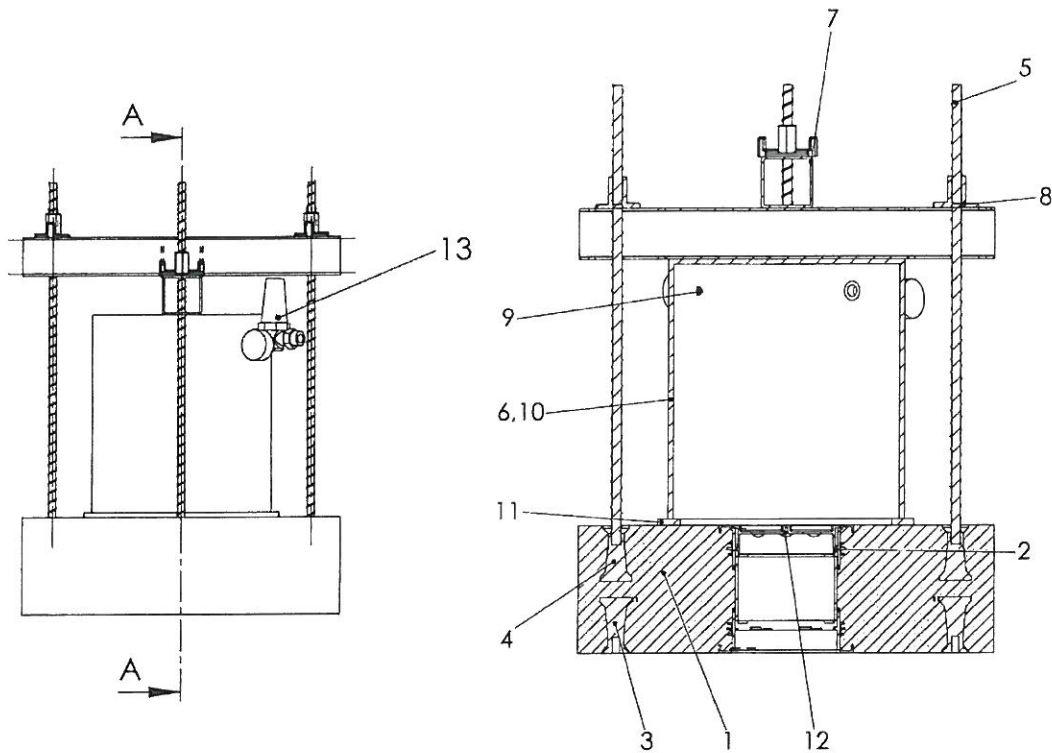

Figure 2: Test setup



Figure 3: Test specimen





Item	Designation	Standard	Material
13	Pressure reducing regulator		ABS rubber
12	Cover version 2		EPDM 55+/- Shore A
11	Rubber seal		
10	Bleed valve		
9	Pressure gauge		
8	Spindle rod nut		1.4301
7	Square tube		1.4301
6	Pressure cap welded part		St37
5	Formwork ties		
4	Climax protective cover		
3	Climax sleeve with nail cap		
2	HIS 150-K2/200		
1	Touchstone		C35 / C45 Concrete

Figure 4: Test setup (Manufacturer drawing)



### 3 Test results

Subsequent the manometer display at the beginning and at the end of the tightness test is shown in Figure 5.

For example causal for the minor pressure decrease may be the hygroscopic properties of the concrete as well as a decrease of the tension force of the tension rods for the pressure bell fixing. A water discharge in the area of the sealing could not be detected.

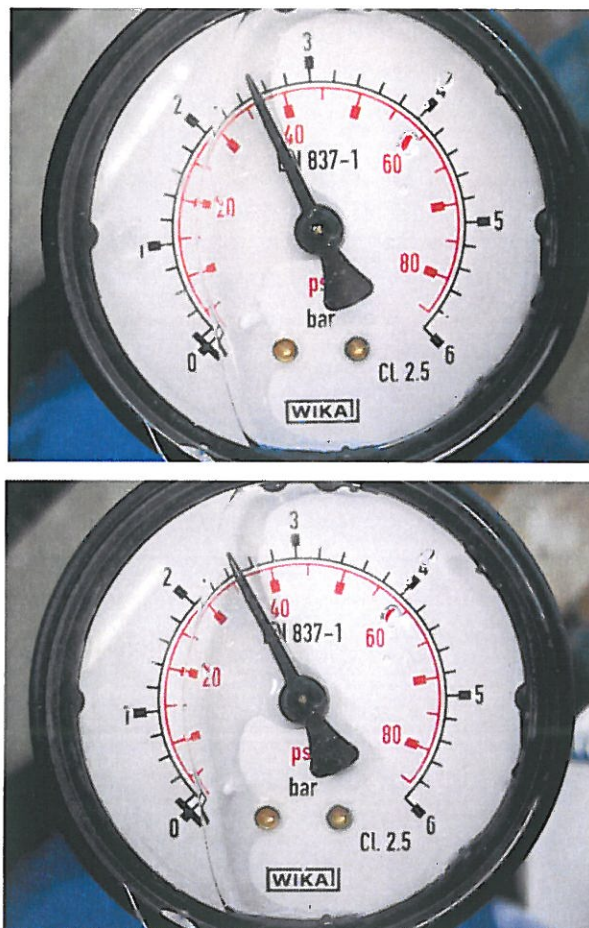

Figure 5: Tightness test with water filled pressure bell (above: manometer display at the beginning of the test at 11/18/2009 10:15; below: manometer display at the end of the test at 11/19/2009 10:20)



#### 4 Summary

*During the tightness test (double packing HSI 150-K2 and sealing cover HSI 150-D) with water filled pressure bell with a nominal pressure of 2,5 bar no defect in water tightness as a result of water discharge could be detected.*

Augsburg, January 28<sup>th</sup>, 2010

